

STRAIGHT BULKHEAD JACK SOLDER TYPE

R125.326.009

CABLE .085

Series : SMA

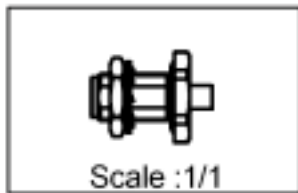
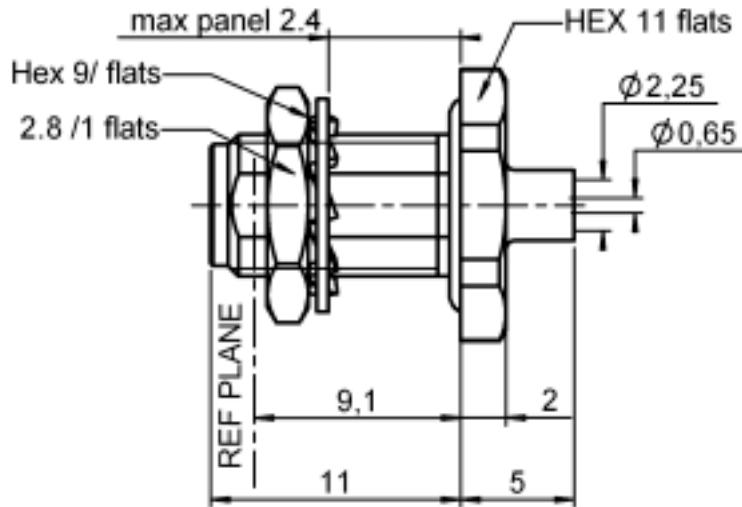

PANEL CUT OUT



mm		
	Maxi	mini
A	6.5	6.4
B	6.15	6

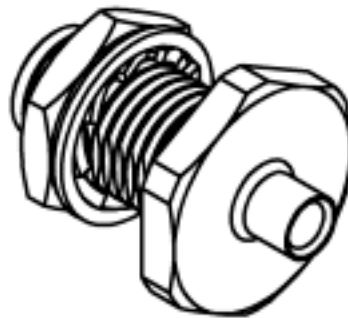

All dimensions are in mm.

COMPONENTS	MATERIALS	PLATING
BODY	BERYLLIUM COPPER	GOLD 1.3 OVER COPPER 0.2 µm
CENTRE CONTACT	BERYLLIUM COPPER	GOLD 2.54 OVER COPPER 2.54 µm
OUTER CONTACT	-	- µm
INSULATOR	PTFE	
GASKET	SILICONE RUBBER	
OTHERS PARTS	BRASS	- µm
-	-	-
-	-	-



Issue : 9840 B

Design changes may be in order to improve the product.

STRAIGHT BULKHEAD JACK SOLDER TYPE

R125.326.009

CABLE .085

Series : **SMA**

ELECTRICAL CHARACTERISTICS

Impedance **50 Ω**
 Frequency **0-18 GHz**
 VSWR **1.07 + 0.008 x F(GHz) Maxi**
 Insertion loss **0.03 √F(GHz) dB**
 RF leakage - (**90 - F(GHz) dB mini**)
 Voltage rating **335 Veff Maxi**
 Dielectric withstanding voltage **750 Veff mini**
 Insulation resistance **5000 MΩ mini**

SPECIFICATION

Stripping	a	b	c	d	e	f
mm	3.17	0.00	0.00	0.00	0.00	0.00

Assembly instruction : **Solder 01**

Recommended cable(s)
 KS 1
 RG 405

Cable retention
 - pull off **130 N mini**
 - torque **NA N.cm**

MECHANICAL CHARACTERISTICS

Centre contact retention
 Axial force – Mating end **NA N mini**
 Axial force – Opposite end **NA N mini**
 Torque **NA N.cm mini**

Recommended torque
 Mating **NA N.cm**
 Panel nut **150 N.cm**
 Clamp nut **NA N.cm**
 A/F clamp nut **0.000 mm**

Mating life **500 Cycles mini**
 Weight **0.000 g**

TOOLING

Part Number	Description	Hexagon
.	.	.
R282.051.000	STRIPPING TOOL	
R282.063.000	POINTER GAUGE	
R282.862.060	CONTROL GAUGE	
R282.744.011	SOLDERING POSITIONER	
R282.914.010	DIELETRIC RECESS GAUGE	
R282.730.043	INSULATOR MOUNTING TOOL	
R282.744.220	SOLDERING POSITIONER (CENTER CONTACT)	
R282.740.000	SOLDERING MOUNTING	
R282.915.010	DIELECTRIC RECESS TOOL FOR DIELETRIC	

ENVIRONMENTAL

Operating temperature **-65/+105 °C**
 Leakage – pressurised only **NA Atm.cm3/s**
 Hermetic seal **NA Mpa**

OTHERS CHARACTERISTICS



Issue : **9840 B**

Design changes may be in order to improve the product.